

ETATRACK active 1000



Active Solar Tracking System

Characteristics

- total module surface up to 10 m²
- maintenance-free
- high reliability and life expectancy
- low power consumption, ca. 1.25 kWh/year
- no unnecessary tracking movements
- no failure prone light sensor
- designed to withstand wind speed up to 150 km/h
- cost-efficient tracking system

Application

Single-axis solar tracking increases the energy return of solar modules by 25 to 35 % per year in average, dependent on location, respectively up to 55 % during summer months.

Tracking

- angle East-West: 90°, active
- elevation angle: 0° - 45°, manually adjustable
- no separate sensors, it uses the modules as sensor
- energy supply of tracking drive: 12 V nominal, max. 200 V (Voc), provided by one of the tracked modules
- horizontal position at night
- tracking in steps according to the daily sunshine duration

Module Surface And Fixation

- 10 m² total module surface (up to 1.6 kWp, dependent on module type)
- fixation: movable stainless steel clips, fitting for most module types; no drilling of additional holes into the module frame

Mounting And Foundation

- mounting pole: length 2.5 m
- surface concrete foundation (approx. 1.6 m²)

Included In Delivery

- frame and fixation elements made of steel, Zn-coated, stainless steel clips for modules
- electronics incl. battery in plastic housing
- linear motor
- mounting pole

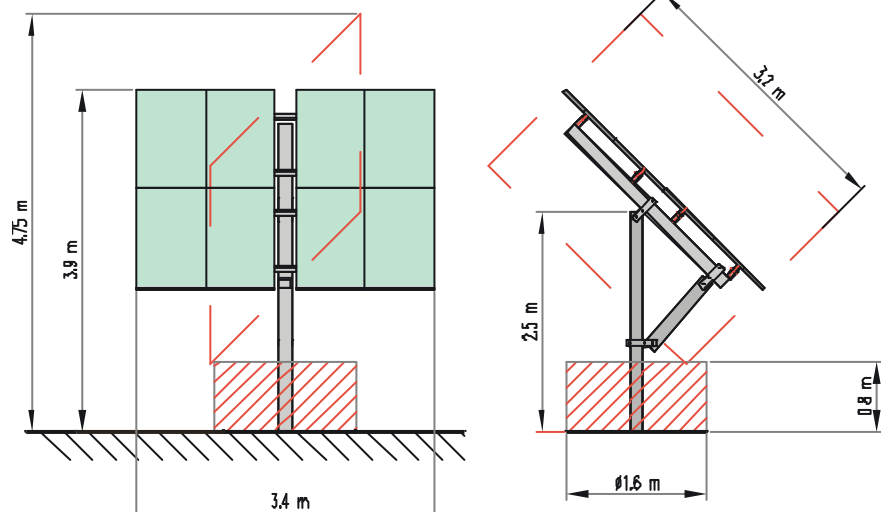

example of system dimensions for 8 x modules BP 3160 (1,280 Wp)